

Ingenic[®] RD4770_PISCES

Development Board

Hardware Manual

Version: 1.1

Date: 2011.5



北京君正集成电路股份有限公司
Ingenic Semiconductor Co., Ltd.

Ingenic RD4770_PISCES Development Board

Hardware Manual

Copyright © Ingenic Semiconductor Co. Ltd 2011. All rights reserved.

Release history

Date	Revision	Change
2011.5	1.1	First release

Disclaimer

This documentation is provided for use with Ingenic products. No license to Ingenic property rights is granted. Ingenic assumes no liability, provides no warranty either expressed or implied relating to the usage, or intellectual property right infringement except as provided for by Ingenic Terms and Conditions of Sale.

Ingenic products are not designed for and should not be used in any medical or life sustaining or supporting equipment.

All information in this document should be treated as preliminary. Ingenic may make changes to this document without notice. Anyone relying on this documentation should contact Ingenic for the current documentation and errata.

Ingenic Semiconductor Co., Ltd.

Junzheng Bld, Zhongguancun Software Park 2 Dongbeiwang West Road, Haidian District Beijing, China, 100193

Tel: 86-10-56345000

Fax: 86-10-56345001

Http: //www.ingenic.cn

Content

1	Overview	1
1.1	Functions of RD4770_PISCES	1
1.2	RD4770_PISCES System Architecture	2
2	Hardware Description	3
2.1	RD4770_PISCES board picture	3
2.2	Power	3
2.3	System Reset	4
2.4	System boot mode	4
2.5	SYSTEM MEMORY(DDR2 SDRAM)	4
2.6	NAND extended card	4
2.7	LCD interface and Expansion card	5
2.7.1	LCD interface definition	5
2.7.2	LCD Expansion card	6
2.8	USB Interface	6
2.9	Audio System	6
2.9.1	Headphone	6
2.9.2	MIC	6
2.9.3	Speaker	6
2.9.4	I2S Expansion slot	6
2.10	Video out	6
2.11	Keypad Interface	6
2.12	MMC/SD TF card	6
2.13	Debug Board Interface	6
2.14	System Status LED	7
2.15	FM Module	7
2.16	OWI bus	7
2.17	TS interface	7
2.18	SPI interface	7
2.19	CIM interface	8
2.20	GPS interface	8
2.21	EPD interface	8
2.22	PS2 interface	10
2.23	EFUSE	10
3	Quick start RD4770_PISCES board	11
4	Appendix: GPIO Definition	13

1 Overview

JZ4770 is a multimedia application processor, which has a very high performance and low power 32-bit RISC engine. JZ4770 integrates various peripherals for embedded application, such as memory controller, USB1.1 host and USB OTG interface, On-chip audio CODEC, multi-channel SAR-ADC, LCD controller, CMOS sensor interface, MMC/SD controller, GPS baseband controller, SSI interface, I2C interface, Camera interface, TS interface, TV OUT, UART, LVDS interface, 1-wire, OTP, GPIO, and so on.

The RD4770_PISCES is a reference design with JZ4770 addressing to consumer electronic equipment that help engineer to quickly develop their own products in hardware and software. This design also provides flexible interface to extend other module.

With this reference design, there have richness development package include Android(default), Linux, WinCE and MiniOS.

1.1 Functions of RD4770_PISCES

- CPU: 1GHZ supports Android(default), Linux, WinCE and MiniOS.
- DDR2 SDRAM: V59C1G02168QBPx2, 512MB.
- iNAND FLASH: FLASH extended card, TOSHIBA THGBM3G5D1FBA1E, 4G BYTE .
- SPI FLASH S25FL064(optional).
- LCD: 800x480 5.0inch TFT with touch panel and support EPD panel.
- Multimedia: Support every multimedia software De/Encoder. Video can support CVBS output.
- LVDS interface: LVDS panel
- FM module(option).
- 7 keys can provide soft power on/off and extended application etc.
- USB1.1 Host / USB OTG interface.
- TS interface: High speed SPI interface can extend DTV module.
- UART: 2-wire RS232, GPS+GSM module extension.
- Camera interface: Compatible 8-bit ITU656 camera.
- MMC/SD TF extended interface can support SDIO interface.
- Backlight control with PWM.
- Advanced power manager: Lithium battery charge; support RTC alarm and power up; very low power consumption; battery charging status indicator and battery voltage monitor.

1.2 RD4770_PISCES System Architecture

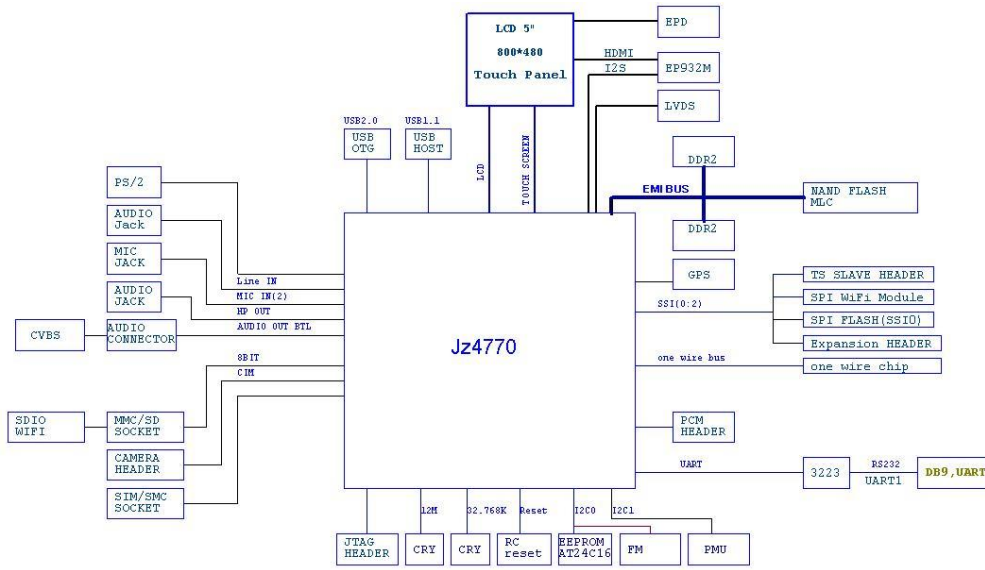

Figure 1-1 RD4770_PISCES System Architecture

2 Hardware Description

In this section, we describe every hardware module of the board. Please refer to the user's guide of JZ4770 first. For the other components, please refer to relative datasheet. For the details of the board, please refer to RD4760_LEPUS schematic design.

2.1 RD4770_PISCES board picture

Figure 2-1 shows the picture of the main components and connectors.

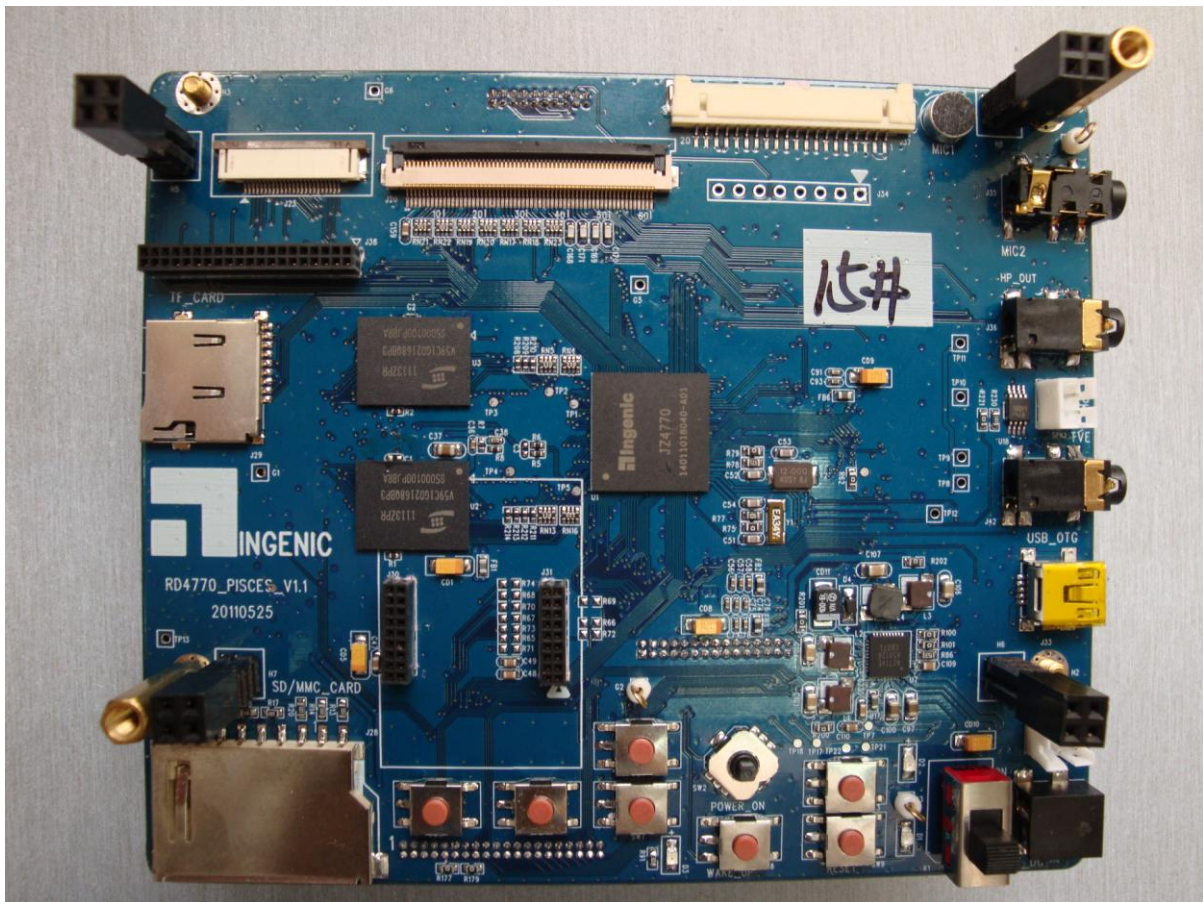

Figure 2-1 RD4770_PISCES board

2.2 Power

The RD4770_PISCES board is powered by 5V adapter or USB. K1 is power on/off switch. SW8 is hibernate/wakeup key. It also can be powered by Lithium Battery.

When power is on and system is running, push SW8 for several seconds. It will assert an interrupt to CPU, and CPU will set PW_ON low to power off the board. When long push SW8 again PW_ON is high and power is on (software on/off).

The main power chip U7(ACT8600) which is power manage unit can support +3.3V, +1.8V and

+1.2V. LED-D3 indicates +3.3V power. U7 out9 is RTC power that support +3.3V.

J32 is external power supply jack. It should be connected with 5V-2A DC adapter that power system and charge up battery. Adapter supply current limit is 1A. LED D2 indicates the charge status when charging. CPU can realize charge state through I2C access PMU's register.

This board also can be powered and charged the battery by USB. Supply current limit is 450mA .The PRI is adaptor, USB port and Li battery.

2.3 System Reset

When power on, PMU U7 can provide system reset signal to CPU, extended card and debug card. SW9 is the manual reset button.

2.4 System boot mode

RD4770_PISCES has five boot modes:

- USB
- Nand Flash
- SPI Flash
- SD/MMC (MSC0, default ,Share NAND Flash interface)
- iNAND

Remove R28,R20,R31-R34 and connect R65-R70 when boot from SD/MMC card.

Connect R71-R74 when boot from SPI Flash.

Table 2-1 describes the setting of boot start:

Table 2-1 BOOT SETUP

Hold Push Key	Boot status
SW7	SPI Boot
SW6+SW7	Nand Boot
SW6	USB Boot
None	SD/MMC Boot (Power on Default)
SW5+SW6+SW7	iNAND Boot

2.5 SYSTEM MEMORY(DDR2 SDRAM)

RD4770_PISCES has two chips, 32bit bus width, 8Banks X 16M X 16 Bit, 512MByte DDR2 SDRAM.

2.6 iNAND extended card (Share NAND Flash interface)

J30, J31 are NAND Flash extended slot, default configuration TOSHIBA's iNAND THGBM3G5D1FBA1E ,4G BYTE.

2.7 LCD interface and Expansion card

2.7.1 LCD interface definition

J20 is the LCD interface, which can directly connect to LCD Expansion card. RD4770_PISCES can support serial/parallel interface(ITU656/601), 18/24bit RGB TFT panel; delta RGB TFT panel; smart LCD and STN panel. It also contains I2C and SPI interface for suitable use.

Table 2-2 LCD Interface (J20) Signals Definition

Pin Number	Signal	Pin Number	Signal
1	GND	2	GND
3	+3.3V	4	+3.3V
5	GND	6	LCD_D_R0
7	LCD_CLS	8	LCD_D12
9	LCD_D13	10	LCD_D14
11	LCD_D15	12	LCD_D16
13	LCD_D16	14	GND
15	LCD_SPL	16	LCD_PS
17	LCD_D6	18	LCD_D7
19	LCD_D8	20	LCD_D9
21	LCD_D10	22	LCD_D11
23	GND	24	LCD_D_B0
25	LCD_REV	26	LCD_D0
27	LCD_D1	28	LCD_D2
29	LCD_D3	30	LCD_D4
31	LCD_D5	32	GND
33	LCD_D_PCLK	34	GND
35	LCD_HSYNC	36	LCD_VSYNC
37	LCD_DE	38	GND
39	VDD_TP	40	XP
41	YN	42	XN
43	YP	44	VSS_TP
45	GND	46	I2C_SDA
47	I2C_SCK	48	GND
49	SSI1_DT	50	SSI1_CLK
51	SSI1_CE0_N	52	GND
53	LCD_DISP_N	54	LCD_RESET_N
55	LCD_INT	56	PWM4/BL_EN_N
57	BAT-V	58	BAT-V
59	GND	60	GND

There are some special signals: 1-LCD_SPL; 2-LCD_CLS; 3-LCD_PS; 4-LCD_REV. For details please refer to JZ4770 datasheet.

2.7.2 LCD Expansion card

RD4760_LEPUS_LCD_BOARD_V1.3 is the LCD expansion card. J1 is the connector with 60 pin FPC to motherboard. J2 is LCD slot which connected KD50G9-40NM LCD panel default.

Backlight circuit is RT9293 (U1). Please attend drive current when use other LCD panel (refer to RT9293 datasheet). Adjust R2 can get suitable drive current. Backlight of LCD panel can be adjusted by software of PWM.

2.8 USB Interface

RD4770_PISCES support USB OTG. There are one MiniAB USB port on main board (J33). It contains insert detect circuit. A USB 1.1 host port is on debug board, which can support 500mA current.

2.9 Audio System

2.9.1 Headphone

JZ4770 provides an internal I2S/AC97 audio CODEC and 24bits DAC/ADC. User can connect other external CODEC. The audio system use internal CODEC to implement the input and output of audio. J36 is 3.5mm standard headphone jack. The chip can support up to 16 ohm load.

2.9.2 MIC

M1 is capacitive mic and J35 is mic jack.

2.9.3 Speaker

SPK1 is audio power connector which can support stereo speaker. 1W output for 8 ohm load.

2.9.4 I2S Expansion slot

J34 is a 4-pin synchronized I2S interface with PCM form, 8/16 bit data, used for connects with blue tooth module.

2.10 Video out

The JZ4770 includes dual 10bit Video digital to analog converters (DAC) that can produce CVBS signal on J42.

2.11 Keypad Interface

There are five keys reserved for extending accessorial application by software control (SW1, SW3, SW5, SW6, SW7). SW2 is five directional key contains interrupt signal.

2.12 MMC/SD TF card

J28 is the MMC/SD card socket for extension memory, supports MMC or SD card (Hardware changes, it can boot from SD). J29 is the TF card socket. The power on both socket can be turn off by software.

2.13 Debug Board Interface

In order to make the system debugging facility, there is a debug board connecting to the main

board through head J26 and J27. It provides JTAG port, UART port (DB9,2-wire RS-232) and 10/100MBASE Ethernet port (RJ45).

2.14 System Status LED

There are three LEDs for system status indicator:

- LED D3 indicates the +3.3V power status.
- LED D1 indicates system reset status.
- LED D2 indicates the charge status that light when charging.

2.15 FM Module

There has FM Module on board which can receive FM radio signal and play back through internal CODEC. It is control by I2C signal.

2.16 OWI bus

On the RD4770_PISCES board provides U5: DS2401 (optional), the 48-bit series number chip, compatible with the 1-wire protocol.

2.17 TS interface

J40 is TS interface, which can support PID filtering.

2.18 SPI interface

The high speed SPI interface supports 54MHz, 17Bit serial data. It is coupled with J40 and can be connected Bluetooth, Wifi or ADDA converter.

Table 2-3 TS interface (J40) Signals Definition

Pin Number	Signal	Pin Number	Signal
1	GND	2	VCC1.8V
3	RESET_N(global)	4	VCC1.8V
5	NC	6	NC
7	I2C_SCK	8	VCC3.3V
9	I2C_SDA	10	VCC1.2V
11	GND	12	VCC3.3V
13	VCC3.3V	14	GND
15	SSI0_DT	16	SSI0_CLK
17	SSI0_CE1_N	18	SSI0_DR
19	GND	20	NC
21	NC	22	NC
23	NC	24	NC
25	NC	26	TS_INT0
27	NC	28	TS_INT1
29	TSFAIL	30	TSCLK
31	TSSTR	32	TSFRM
33	TSDI7	34	TSDI6

35	TSDI5	36	TSDI4
37	TSDI3	38	TSDI2
39	TSDI1	40	TSDI0

2.19 CIM interface

J38 is RD4770_PISCES camera interface can support CMOS and CCD Decoder(CCIR656 data format, RGB/YCbCr color).

Table 2-4 CIM interface (J38) Signals Definition

Pin Number	Signal	Pin Number	Signal
40	CIM_D0	39	CIM_D1
38	CIM_D2	37	CIM_D3
36	CIM_D4	35	CIM_D5
34	CIM_D6	33	CIM_D7
31	CIM_VSYNC	32	CIM_HSYNC
29	CIM_MCLK	30	CIM_PCLK
27	CIM_D10	28	CIM_PD_N
25	CIM_D9	26	CIM_RST_N
23	SCC_RST_N	24	CIM_D8
21	SCC_DATA	22	SCC_CLK
19	GND	20	SCC_CD_N
17	NC	18	NC
15	NC	16	NC
13	3.3V	14	GND
11	GND	12	3.3V
9	2C0_SDA	10	1.2V
7	I2C0_SCK	8	3.3V
5	NC	6	CIM_D11
3	NC	4	1.8V
1	GND	2	1.8V

2.20 GPS interface

GPS module also can be connected through UART port on RD4770_PISCES. JZ4770 has a GPS baseband controller, which can connect GPS chip. For detail, please refer to JZ4770 datasheet.

2.21 EPD interface

JZ4770 has a EPD controller, support most EPD panel. J23 and J20 are EPD connectors, which can be connect EPD board-RD4760_LEPUS_EPД_V1.0 through 60 pin FPC. J20 is also LCD connector, but can not connect both boards.

Table 2-5 EPD interface (J20) Signals Definition

Pin Number	Signal	Pin Number	Signal
1	GND	2	GND
3	+3.3V	4	+3.3V
5	GND	6	NC
7	NC	8	NC
9	NC	10	NC
11	NC	12	NC
13	NC	14	GND
15	SDCE_L0	16	SDCE_L1
17	SDDO4	18	SDDO5
19	SDDO6	20	SDDO7
21	NC	22	NC
23	GND	24	GDRL
25	GDSP	26	GDOE
27	SDSHR	28	SDDO0
29	SDDO1	30	SDDO2
31	SDDO3	32	GND
33	SDCLK	34	GND
35	SDLE	36	GDCLK
37	SDOE	38	GND
39	NC	40	NC
41	NC	42	NC
43	NC	44	GND
45	GND	46	I2C_SDA
47	I2C_SCK	48	GND
49	NC	50	NC
51	NC	52	GND
53	NC	54	NC
55	NC	56	NC
57	BAT-V	58	BAT-V
59	GND	60	GND

Table 2-6 EPD interface (J23) Signals Definition

Pin Number	Signal	Pin Number	Signal
1	NC	2	GND
3	PWR0	4	PWR1
5	PWR2	6	NC
7	NC	8	NC
9	NC	10	NC
11	SDCE_L2	12	NC

13	NC	14	NC
15	PWRCON	16	NC
17	NC	18	NC
19	GND	20	AUX
21	EPD_BD0	22	EPD_BD1
23	EPD_BD2	24	EPD_BD3

2.22 PS2 interface

Test point(TP8~TP13) is ps2 interface, users can connect ps2 device such as keyboard and mouse. For detail, please refer to JZ4770 datasheet.

2.23 EFUSE

JZ4770 provide EFUSE function,users can program as needed EFUSE.AVDEFUSE pin should be kept 0v except during program.Maximum accumulateive time for AVDEFUSE pin exposed under 2.5V should be less than 1 sec. For detail,please refer to JZ4770 datasheet.

3 Quick start RD4770_PISCES board

When you get the RD4770_PISCES board, it has been initialized with Android system. Before power on the board, please do the following step:

- Connecting the debug board;
- Connecting serial port – UART to a host PC as console, the configuration is 57600-8N1;
- Connecting a battery to BT1, external DC power adaptor (5V-2A) or USB port;

Keys introduction:

- SW8: system power on/off and wakeup manual. Long pushing will turn on the board, once again will turn it off. When in sleep mode, long pushing will wake up the system.
- SW9: system reset manual.

Start Android system (default):

After power on the board, there will be output on the console via serial port and LCD panel. After a moment, the demo application will be launched, you will go into a rich and colorful multimedia world.

4 Appendix: GPIO Definition

in Number	Default Port Name	Name for Real Size	Direction	Active	Function
L3	CS5_N/PA25	SD0_CD_N	Input	Low	SD card plug-in detection
M3	CS6_N/RDWR_N/PA26	SD0_WP_N	Input	Low	SD card write protection
J3	SA2/PB2	SD1_CD_N	Output	Low	TF card plug-in detection
G1	SA3/PB3	KEY_INT	Input	High	Navigation switch ADC trigger INT
L5	SA5/DACK1/FRB1_N PB5	USB_DETE	Input	High	USB insert detection
F21	UART3_TXD/PWM5 SCLK_RSTN/PE5	LCD_REST_N	Output	Low	LCD reset
J17	UART3_CTS_N BCLK_AD/PE8	NET_RESET_N	Output	High	Net reset
H20	UART3_RTS_N LRCLK_AD/PE9	SD1_VCC_EN_N	Output	Low	TF card power control
AA6	SSI0_GPC/SSI1_GPC PE19	PMU_IRQ_N	lutput	Low	PMU IRQ
AA21	PF19	GPS_PWR_EN	Output	High	GPS Power enable
U19	PF20	SD0_VCC_EN_N	Output	Low	SD card power control
K17	PF21	JD	Input	Low	Headphone insert detection
V19	PF22	PCM_RST_N	Output	Low	PCM reset
P10	PWM0/PE0	LCD_INT	lutput	High	LCD panel Interrupt
U10	PWM1/PE1	LCD_PWM	Output	Low	LCD backlight bright trimming
W1	PWM2/PE2	LCD_DISP_N	Output	Low	LCD panel internal power enable
N5	PWM3/PE3	CIM_RST_N	Output	Low	Camera reset
P5	PWM4/PE4	CIM_PD_N	Output	Low	Camera powerdown
W13	PWM6/PD10	TS_INT0	lutput	Low	TS Interface Interrupt 0
P12	PWM7/PD11	TS_INT1	lutput	Low	TS Interface Interrupt 1
W6	EXCLKO/PD15	GPS_OSC_EN	Output	High	GPS osc enable
E1	WE_N/PA17	SHUTDOWN_N	Output	Low	Audio power amplifier shutdown
D2	RD_N/PA16	AVDEFUSE_EN_N	Output	Low	AVDEFUSE power enable
T12	SCC_DATA/PD8	TS_RST_N	Output	Low	TS reset