

# Ingenic<sup>®</sup> RD4755\_CETUS

## Reference Design

Hardware Manual

---

Version: 1.3

Date: Oct. 2009



北京君正集成电路有限公司  
Ingenic Semiconductor Co. Ltd

# Ingenic RD4755\_CETUS Reference Design

## Hardware Manual

Copyright © Ingenic Semiconductor Co. Ltd 2009. All rights reserved.

### Release history

Date	Revision	Change
Aug. 2009	1.2	First release.
Oct. 2009	1.3	Change audio circuit.

### Disclaimer

This documentation is provided for use with Ingenic products. No license to Ingenic property rights is granted. Ingenic assumes no liability, provides no warranty either expressed or implied relating to the usage, or intellectual property right infringement except as provided for by Ingenic Terms and Conditions of Sale.

Ingenic products are not designed for and should not be used in any medical or life sustaining or supporting equipment.

All information in this document should be treated as preliminary. Ingenic may make changes to this document without notice. Anyone relying on this documentation should contact Ingenic for the current documentation and errata.

### Ingenic Semiconductor Co., Ltd.

Room 108, Information Center Block A

Zhongguancun Software Park, 8 Dongbeiwang west Road,

Haidian District, Beijing China, 100193

Tel: 86-10-82826661

Fax: 86-10-82825845

Http: //www.ingenic.cn

---

## Content

<b>1</b>	<b>Overview.....</b>	<b>1</b>
1.1	Functions of RD4755_CETUS.....	1
1.2	RD4755_CETUS System Architecture .....	2
<b>2</b>	<b>Hardware Description.....</b>	<b>3</b>
2.1	RD4755_CETUS Layout.....	3
2.2	System Power.....	3
2.3	System Reset.....	4
2.4	System boot mode .....	4
2.5	SDRAM .....	4
2.6	NAND extended card .....	5
2.7	LCD interface .....	5
2.8	USB Interface.....	6
2.9	Audio System.....	6
2.10	Video out.....	6
2.11	Keypad Interface.....	6
2.12	MMC/SD TF card (multiplex with Nand Flash and other signals) .....	6
2.13	System Status LED .....	6
2.14	FM Module .....	7
2.15	TS/Camera interface (multiplex with other signals) .....	7
<b>3</b>	<b>Quick start RD4755_CETUS.....</b>	<b>9</b>
<b>4</b>	<b>Appendix: GPIO Definition.....</b>	<b>11</b>



# 1 Overview

JZ4755 is a multimedia application processor with innovative dual CPU core technology and powerful HD video decoding, targeted for portable multimedia applications like PMP and Mobile TV. JZ4755 integrates various peripherals for embedded application, such as memory controller (support 12 bits ECC Nand Flash), On-chip audio CODEC, TV Encoder, multi-channel SAR-ADC, LCD controller, CMOS sensor interface, MMC/SD controller, SSI interface, I2C interface, Camera interface, USB2.0 device interface, UART, IrDA, TS interface, GPIO, and so on.

The RD4755\_CETUS is a reference design with JZ4755 addressing to consumer electronic equipment, which help engineer to quickly develop their own products in hardware and software. This design also provides flexible interface to extend other module.

With this reference design, there have richness development package include supporting Linux™, WinCE™ and so on.

## 1.1 Functions of RD4755\_CETUS

- High-performance processor JZ4755 running up to 400MHZ, supports Linux and WINDOWS CE.
- SDRAM: HY57V561620CT-6 X 2, 64MB.
- FLASH: NAND FLASH extended card, K9GAG08 (MLC), supports up to two dual chips with 2-CS signal or one chip with 4-CS signal.
- LCD: 480X272 4.3inch TFT with touch panel.  
Multimedia: Support every multimedia software De/Encoder FM Module can receive FM radio. Video can Support CVBS or S-video or Component signals.
- 8 keys can provide sound-button and soft power on/off, reset, etc.
- USB2.0 Device interface.
- TS interface: can extend DTV module, compatible 8-bit ITU656 camera.
- UART: support GPS+GSM module extension.
- MMC/SD extend interface.
- Advanced power manager: Lithium-Ion battery charge; support RTC alarm and power up; very low power consumption, battery charging status indicator, and battery voltage monitor.

## 1.2 RD4755\_CETUS System Architecture

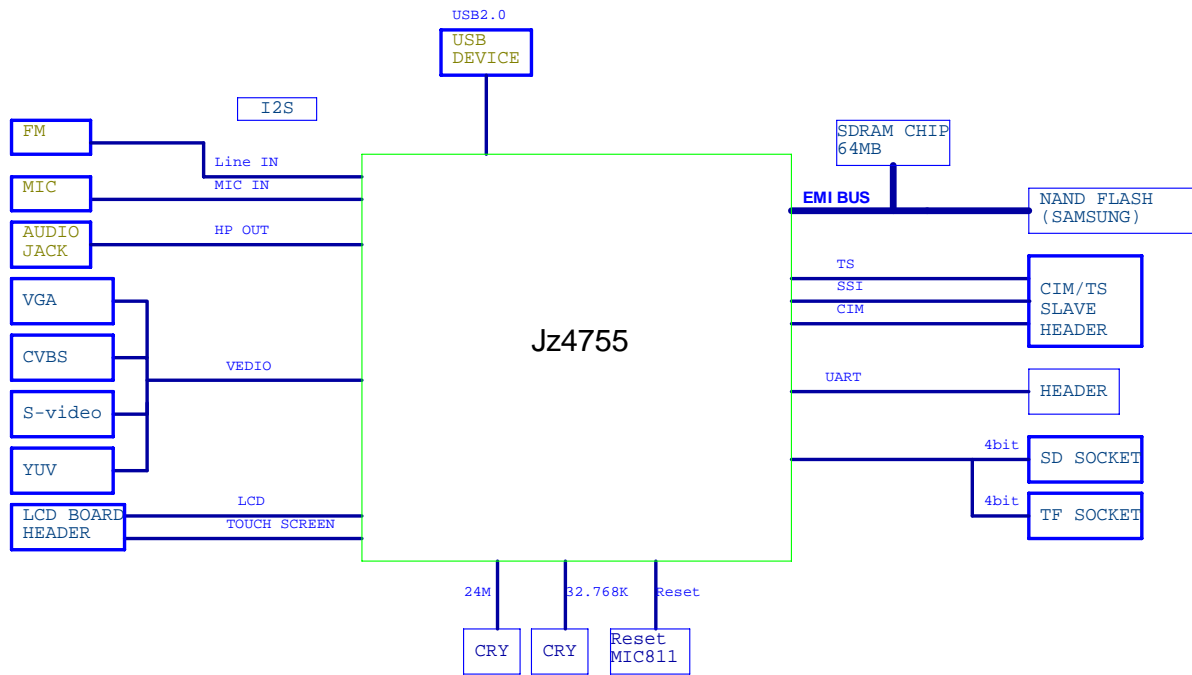

Figure 1-1 RD4755\_CETUS System Architecture

## 2 Hardware Description

In this section, will describe every hardware module of this design, please refer to the user's manual of JZ4755 first. For the other components, please refer to relative datasheet. For the details of the design, please refer to the schematic design.

### 2.1 RD4755\_CETUS Layout

Figure 2-1 shows the layout of main components and connectors.

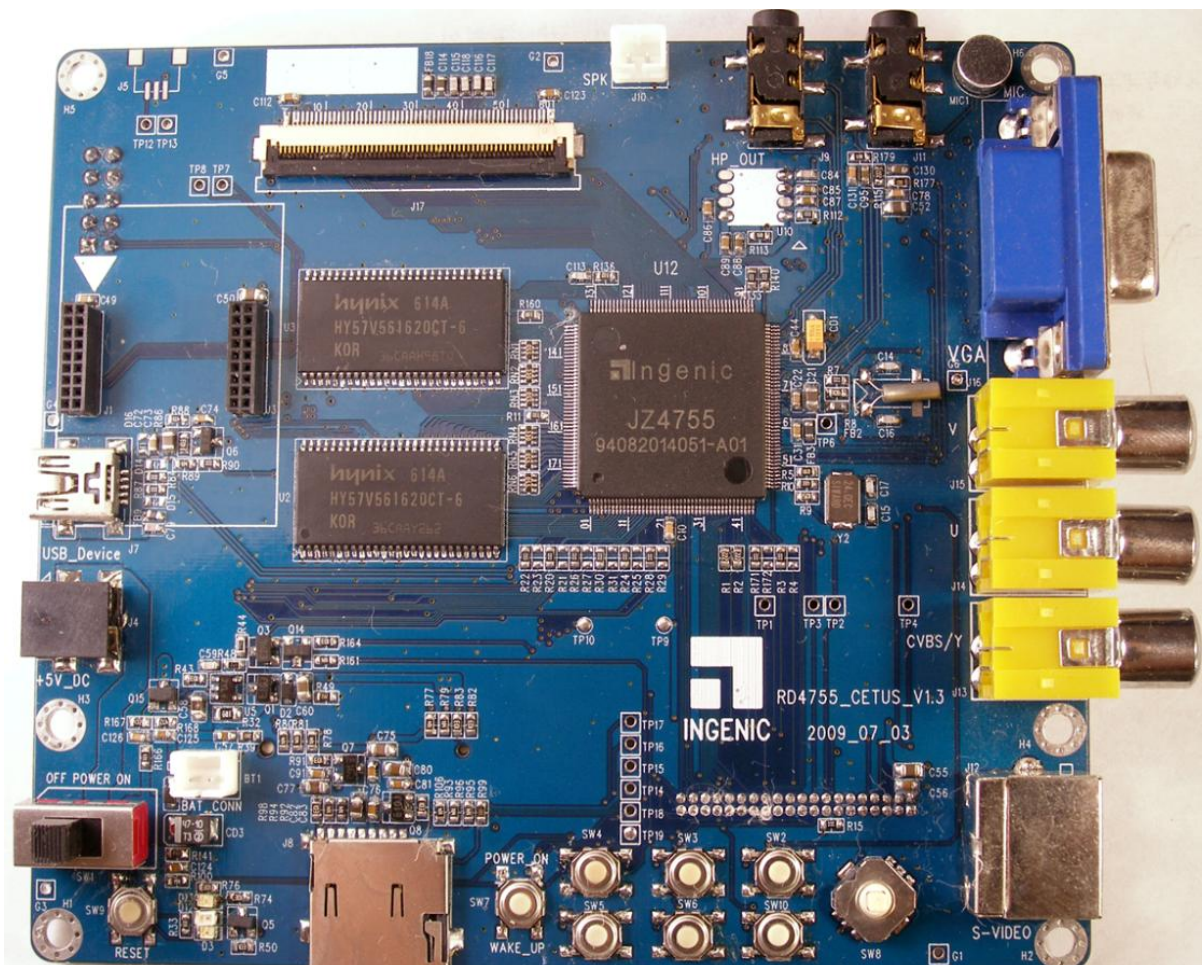

Figure 2-1 RD4755\_CETUS Layout

### 2.2 System Power

The RD4755\_CETUS board is powered by 3.7V Lithium-Ion battery, via header BT1. The button SW7 is power on/off switch. Either adaptor, USB or Battery supply for the board the first, system can power on. As the system is running, long push SW7 will assert an interrupt to CPU, and then the hardware in IC can set PW\_ON port 0 to power off the board after associated processing. And when

long push SW7 again will power on the board and the CPU should output 1 on PW\_ON port in order to turn on the power.

The main power chips are U6 and U7, RT8020, +3.3V, and +1.8V power supply. The LED D12 indicates that +3.3V power is normal.

U8 – XC6206 provides +3.3V power for RTC.

J4 is the external power supply jack, should connect with 5V 2A DC power adapter, together for battery charge. LED D3 indicates the charge status that light when charging, and inform to CPU.

This board also can be powered with USB device port when connect to PC, and charge the battery together. PW\_ON status can adjust the charge circuit that is different in power on (400mA) and off (200mA) status.

## 2.3 System Reset

RC circuit can provide the hardware system reset signal to all components when power on. SW9 is the manual reset button.

## 2.4 System boot mode

RD4755\_CETUS has three modes of boot start:

- Nand Flash ( default )
- USB
- SD/MMC

Table 2-1 describes the setting of boot start:

**Table 2-1 BOOT SETUP**

Hold Push Key	Boot status
None	Nand Flash Boot (Power on Default)
SW10+SW8 wave to Right	USB Boot
SW2	SD card Boot

For details about boot select setting, please refer to the JZ4755 Hardware Manual.

## 2.5 SDRAM

This board has 64MB SDRAM, consist of two chips – U2 and U3, 4Banks X 4M X 16Bit.



## 2.6 NAND extended card

J1 and J3 are the NANDFlash extended slots, can support up to two dual chips with 2 CS signal or one chip with 4 CS signal.

## 2.7 LCD interface

J17 is the LCD interface, which can directly connect to LCD Expansion card. Table 2-1 lists the signals definition of J17.

Table 2-2 LCD Interface (J17) Signals Definition

Pin Number	Signal	Pin Number	Signal
1	GND	2	GND
3	LCD_3.3V	4	LCD_3.3V
5	GND	6	LCD_R0
7	LCD_R1	8	LCD_R2
9	LCD_R3	10	LCD_R4
11	LCD_R5	12	LCD_R6
13	LCD_R7	14	GND
15	LCD_G0	16	LCD_G1
17	LCD_G2	18	LCD_G3
19	LCD_G4	20	LCD_G5
21	LCD_G6	22	LCD_G7
23	GND	24	LCD_B0
25	LCD_B1	26	LCD_B2
27	LCD_B3	28	LCD_B4
29	LCD_B5	30	LCD_B6
31	LCD_B7	32	GND
33	LCD_D_PCLK	34	GND
35	LCD_HSYNC	36	LCD_VSYNC
37	LCD_DE	38	GND
39	VDD_TP	40	XP
41	YN	42	XN
43	YP	44	VSS_TP
45	GND	46	I2C_SDA
47	I2C_SCK	48	GND
49	SSI_DT	50	SSI_CLK
51	SSI_CE0_N	52	GND
53	LCD_DISP_N	54	LCD_RESET_N

55	LCD_INT	56	PWM2
57	BAT-V	58	BAT-V
59	GND	60	GND

## 2.8 USB Interface

There have one one MiniUSB device port on main board (J7).

## 2.9 Audio System

JZ4755 provides an internal CODEC that is I2S/AC97 audio CODEC with 24 bits DAC and 24 bits ADC. The audio system of this design makes use of the internal CODEC to implement the input and output of audio. It consists of MIC-in jack J11, headphone jack J9, FM module U10 (optional), an amplifier for external speaker connecting to the header J10. When plug a headphone in J9, the amplifier will be off.

## 2.10 Video out

The JZ4755 includes three 10-bit Video digital to analog converter (DAC) that can produce standard analog signal TV output with color demodulation of NTSC or PAL. J12 supports Y/C Video output (S-video), J13, J14, J15 output YUV signals, J16 outputs VGA signals.

## 2.11 Keypad Interface

There have six keys reserved for extending accessorial application by software control.

## 2.12 MMC/SD TF card (multiplex with Nand Flash and other signals)

J6 is the MMC/SD card socket for extension memory, supports MMC or SD card. J8 is the TF card socket.

## 2.13 System Status LED

There have three LEDs for system status indicator:

- LED D12 indicates the +3.3V power status.
- LED D13 indicates system reset status.
- LED D3 indicates the charge status that light when charging.

## 2.14 FM Module

There has FM Module on board which can receive FM radio signal and play back through internal Codec.

## 2.15 TS/Camera interface (multiplex with other signals)

J2 is TS/Camera interface.

Table 2-4 TS/ Camera interface (J2) Signals Definition

Pin Number	Signal	Pin Number	Signal
1	GND	2	+1.8V
3	TS_RESET_N	4	+1.8V
5	NC	6	NC
7	I2C_SCK	8	+3.3V
9	I2C_SDA	10	+1.2V
11	GND	12	+3.3V
13	+3.3V	14	+3.3V
15	SSI_DT	16	SSI_CLK
17	SSI_CE1_N	18	SSI_DR
19	GND	20	NC
21	NC	22	NC
23	NC	24	NC
25	NC	26	INT0
27	NC	28	INT1
29	CIM_MCLK/TSFAIL	30	CIM_PCLK/TSCLK
31	CIM_VSYNC/TSSTR	32	CIM_HSYNC/TSFRM
33	CIM_D7/TSDI7	34	CIM_D6/TSDI6
35	CIM_D5/TSDI5	36	CIM_D4/TSDI4
37	CIM_D3/TSDI3	38	CIM_D2/TSDI2
39	CIM_D1/TSDI1	40	CIM_D0/TSDI0



### 3 Quick start RD4755\_CETUS

When you get the RD4755\_CETUS board, it has been initialized with U-Boot, CELinux kernel and file system on the main board. Before power on the board, you should do the following step:

- Connecting serial port – UART to a host PC through UART board as console, the configuration is 57600-8N1;
- Connecting a battery to BT1, or use external DC power (5V, 2A)

Keys introduction:

- SW7: system power on/off and wakeup manual. Pushing it will switch on the board, long pushing will switch off then. When in sleep mode, pushing it will wake up the system.
- SW9: system reset manual.

Start Linux system (default):

After power on the board, there will be output on the console via serial port and LCD panel. After a moment, the demo application will be launched, letting you into a rich and colorful multimedia world.

Note: It is same as with Linux system to start the board which programmed with WINCE system. After power on the board, there will be output on the console via serial port and LCD panel. After a moment, the WINCE application will be launched.



## 4 Appendix: GPIO Definition

Pin Number	Default Port Name	Name for Real Size	Direction	Active	Function
30	CIM_D5/TSDI5	AMPEN	Output	High	Headphone Jack plug-in detect & Audio Amplifier Power control
36	CIM_HSYNC/TSFRM	KEY_INT	Input	High	Navigation switch ADC trigger INT
88	SDATI	LCD_VCC_EN	Output	High	LCD panel power supply control
32	CIM_D7/TSDI7	LCD_INT	Input	High	LCD panel Interrupt
23	PWM2/SYNC	PWM2	Output	Low	LCD backlight bright trimming
89	SDATO	LCD_DISP_N	Output	Low	LCD panel internal power enable
31	CIM_D6/TSDI6	USB_DETE	Input	High	USB plug-in detection
35	CIM_VSYNC/TSSTR	CHARG_DET_N	Input	Low	Battery Charge state indicate
24	CIM_D0/TSDI0	SD0_VCC_EN_N	Output	Low	SD card power control
25	CIM_D1/TSDI1	SD0_CD_N	Input	Low	SD card plug-in detection
26	CIM_D2/TSDI2	SD0_WP_N	Input	Low	SD card write protection
27	CIM_D3/TSDI3	SD1_VCC_EN_N	Output	Low	TF card power control
29	CIM_D4/TSDI4	SD1_CD_N	Input	Low	SD card plug-in detection
37	CIM_MCLK/TSFAIL	DC_DETE	Input	High	DC-adaptor plug-in detection
89	SDATO	INT0	Input	High	TS Interface Interrupt 0
88	SDATI	INT1	Input	High	TS Interface Interrupt 1
15	A15/MSC0_CLK	MSC0_CLK	Output	High	MSC (MMC/SD) 0 clock output
14	A16/MSC0_CMD	MSC0_CMD	Output	High	MSC (MMC/SD) 0 command