



RD_JZ4775_MENSA_BOARD

Schematic Revision 1.1

| Title | Page |
|---------------------|------|
| COVER SHEET | 1 |
| SYSTEM ARCHITECTURE | 2 |
| POWER ARCHITECURE | 3 |
| DDR3 | 4 |
| Nand/Camera | 5 |
| AUDIO/KEY | 6 |
| RTC | 7 |
| LCD/EPD | 8 |
| PMU | 9 |
| IW8101/IW8103 | 10 |
| IW8103B/MT5931 | 11 |
| USB OTG/SD CARD/PCM | 12 |
| DEBUG | 13 |
| HISTORY | 14 |

| | | |
|---------------------------------|--------------------------|-------------|
| INGENIC SEMICONDUCTOR CO.,LTD | | |
| Title RD_JZ4775_MENSA_BOARD | | |
| Size A3 | Document Number COVER | Rev V1.1 |
| Date: Monday, March 22, 2021 | Sheet 1 | of 14 |

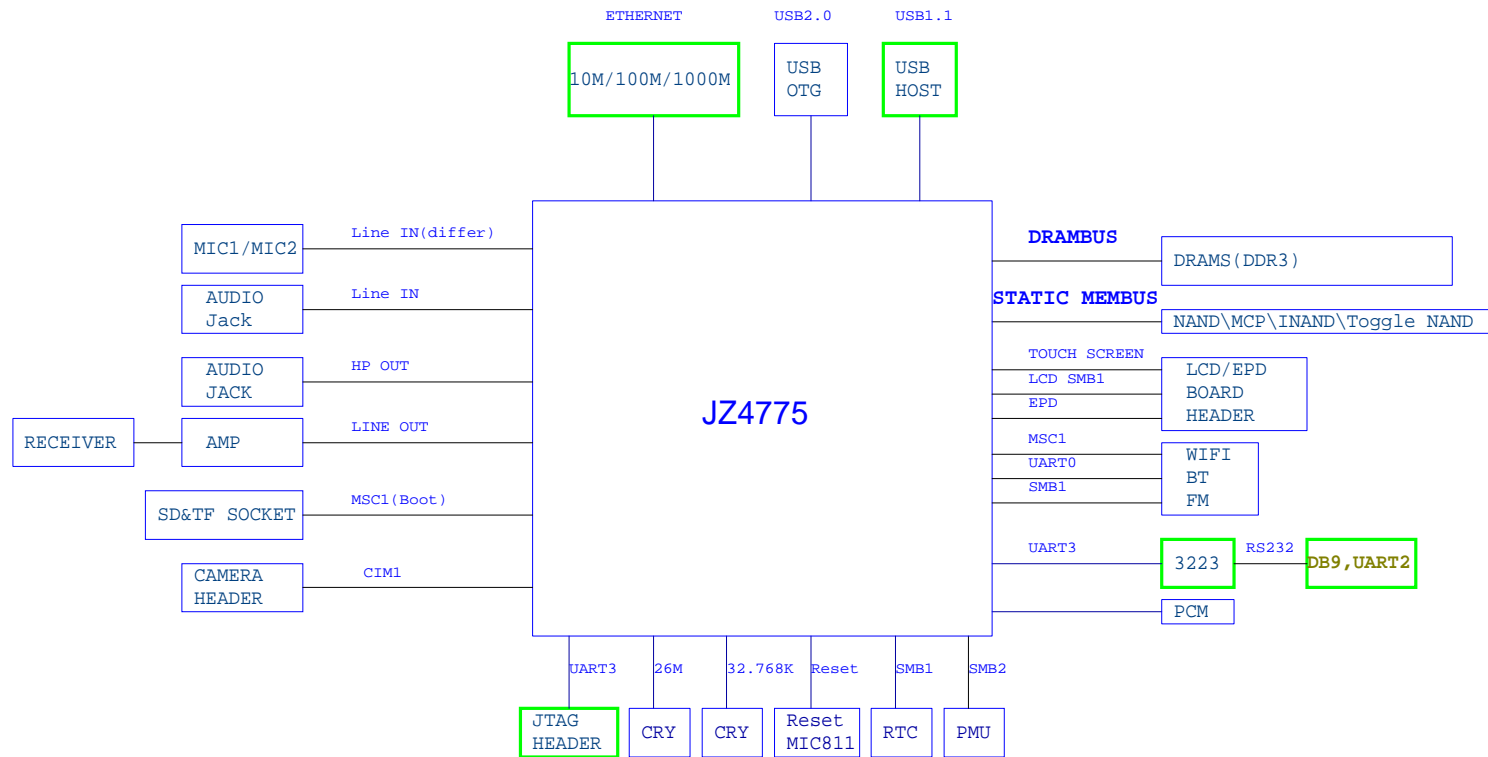

The green color is the debug board

| | | | |
|---------------------------------|--|-------------|--|
| INGENIC SEMICONDUCTOR CO.,LTD | | | |
| Title RD_IJ4775_MENSA_BOARD | | | |
| Size A3 | Document Number SYSTEM ARCHITECTURE | Rev V1.1 | |
| Date: Monday, March 20, 2017 | Sheet 2 | of 14 | |

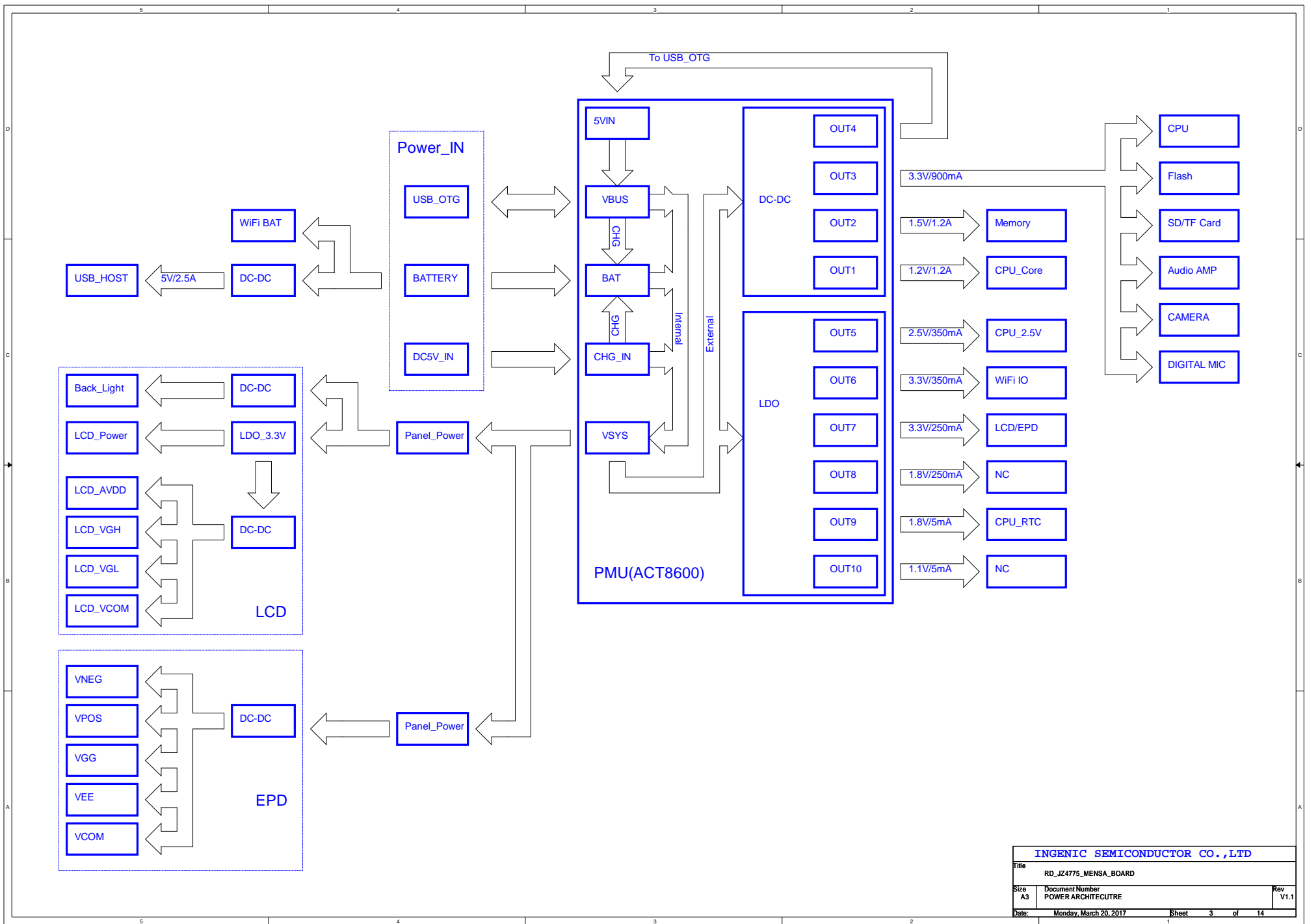

| | | | |
|--------------------------------|---------------------------------------|-------------|--------------------------------|
| INGENIC SEMICONDUCTOR CO.,LTD | | | |
| Title RD_IJ4775_MENSA_BOARD | | | |
| Size A3 | Document Number POWER ARCHITECTURE | Rev V1.1 | Date Monday, March 20, 2017 |
| Sheet 3 | | of 14 | |

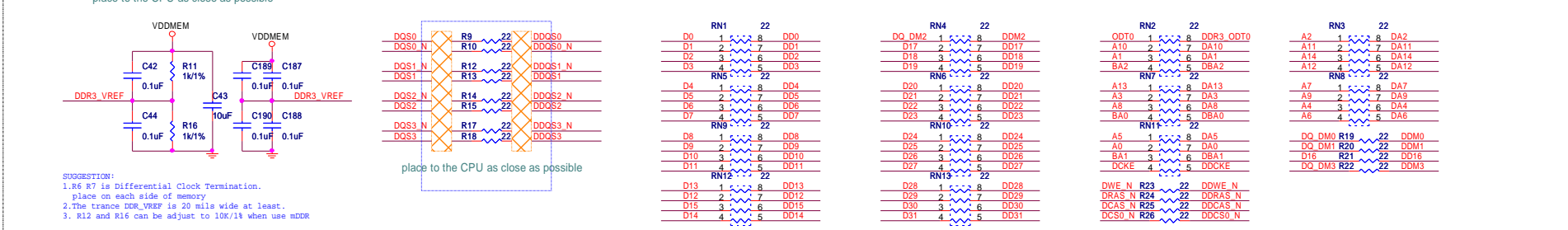
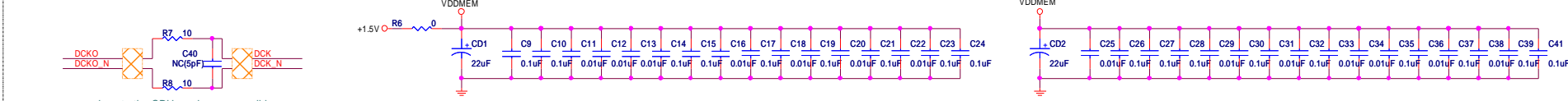
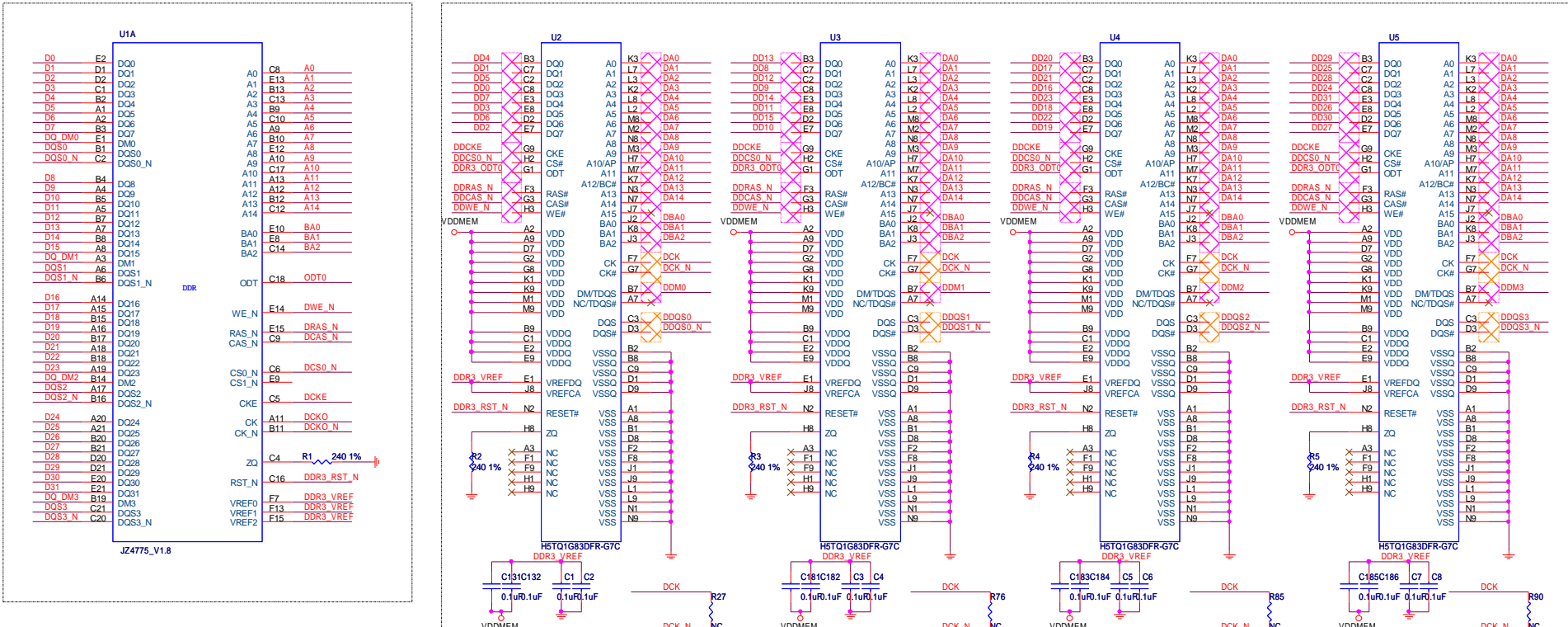

SUGGESTION:
 1. R6 R7 is Differential Clock Termination. place on each side of memory
 2. The trace DQS_VREF is 20 mils wide at least.
 3. R12 and R16 can be adjust to 10K/1Ω when use mDDR

DDR3

Differential pairs
 ZO= 100 ohm

Equi long BUS
 ZO= 50 ohm

| | | | |
|-------------------------------|------------------------|-------|---------|
| INGENIC SEMICONDUCTOR CO.,LTD | | | |
| Title | RD_IJ4775_MENSA_BOARD | | |
| Size | Document Number | | Rev |
| A3 | DDR3 | | V1.1 |
| Date: | Monday, March 22, 2021 | Sheet | 4 of 14 |

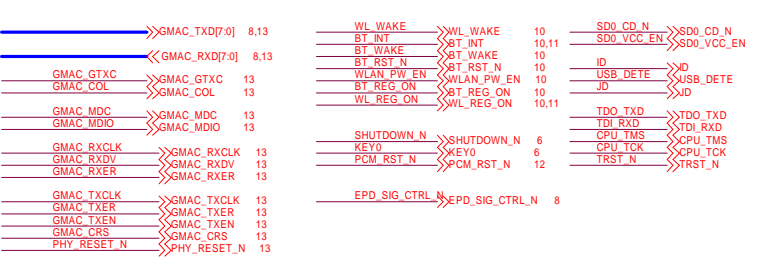
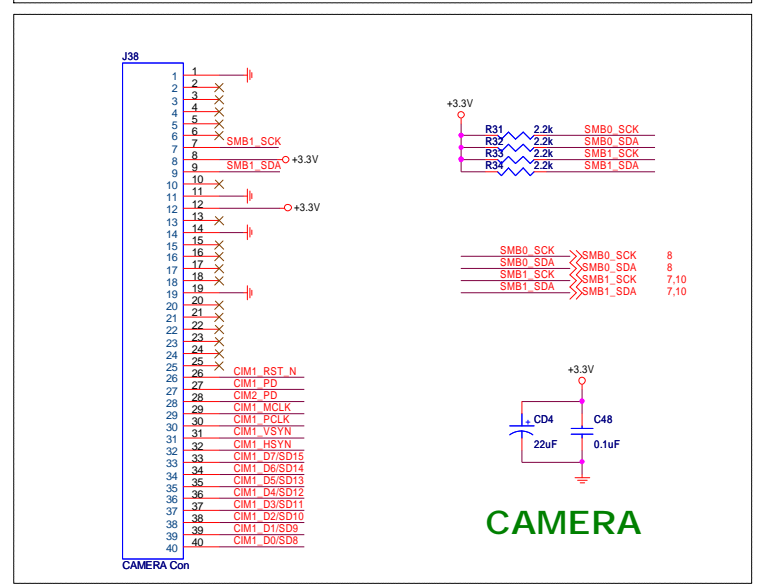
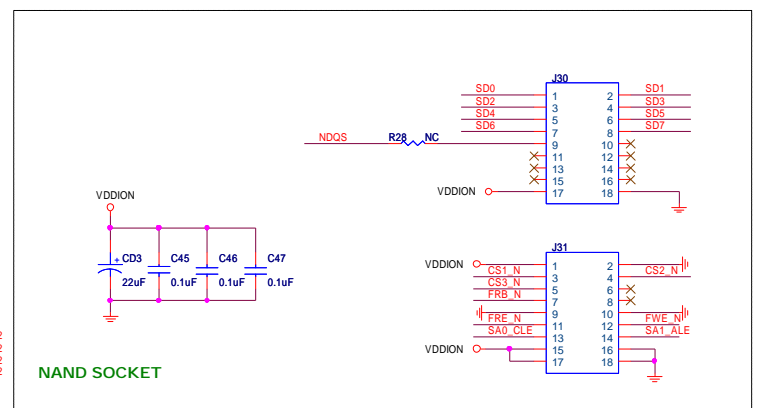
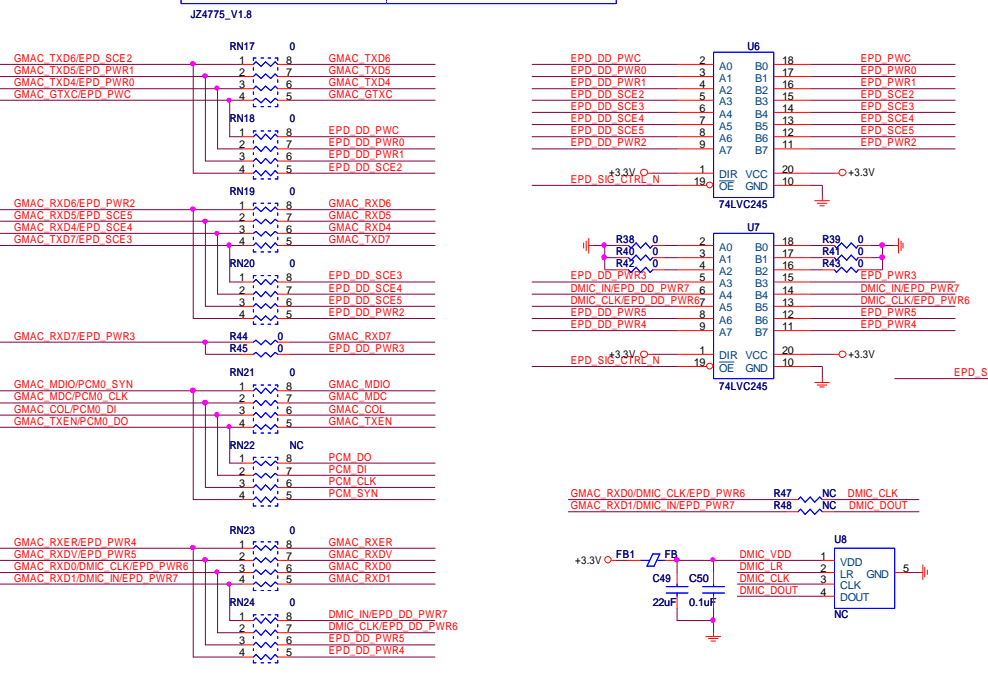
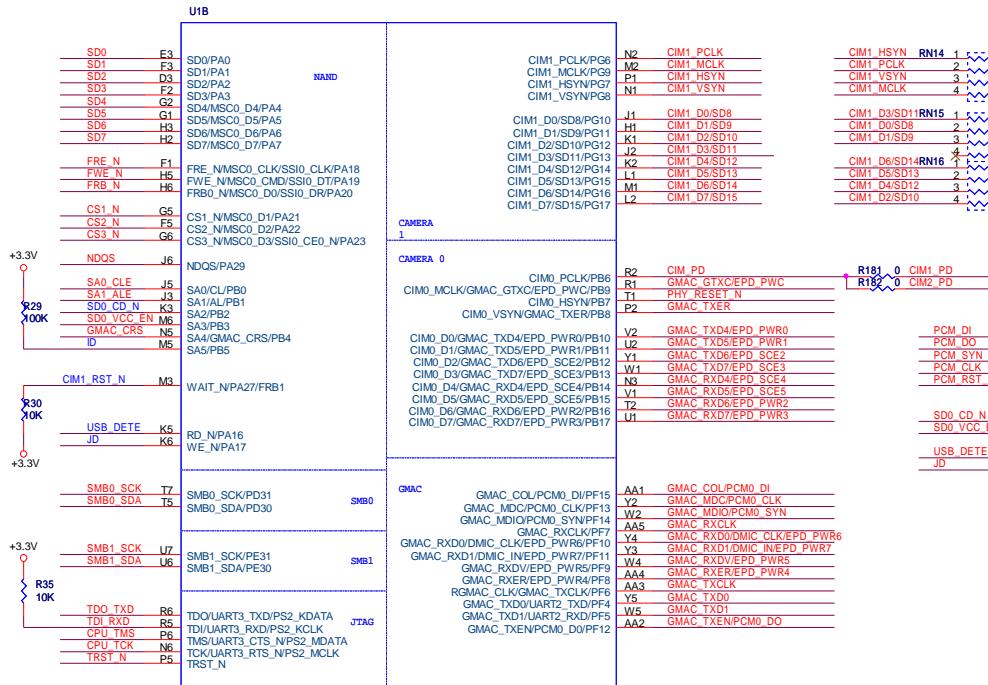

| | | | |
|--|---------------------------------------|--------------------|--|
| INGENIC SEMICONDUCTOR CO., LTD | | | |
| Title RD_IZ4775_MENSA_BOARD | | | |
| Size A3 | Document Number NAND/CAMERA | Rev V1.1 | |
| Date: Monday, March 20, 2017 | Sheet 5 | of 14 | |

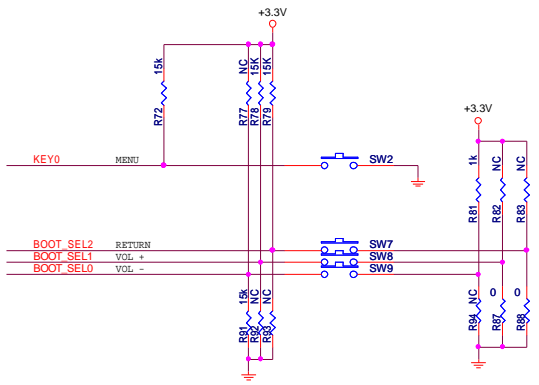
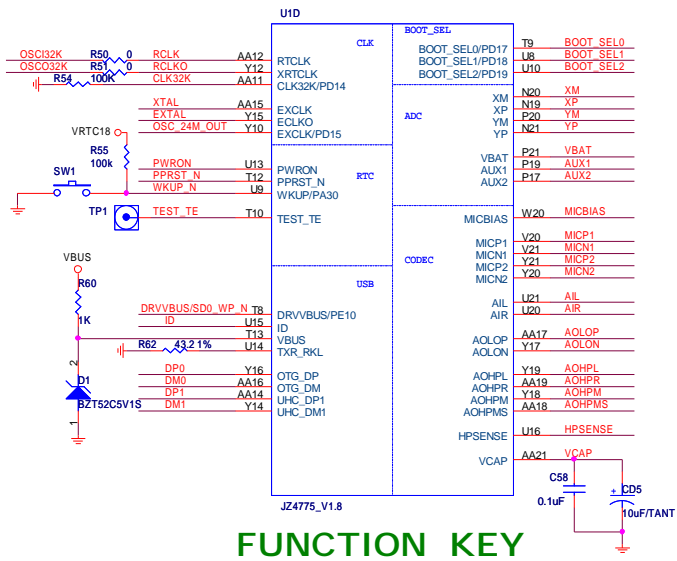

Boot Mode Select

| BOOT_SEL[2:1:0] | BOOT FROM |
|-----------------|---------------|
| 111 | USB Boot |
| 110 | NSND Boot |
| 101 | MSD0 Boot |
| 000 | SP1 Boot |
| 100 | MSC1 Boot |
| 011 | eMMC Boot |
| 010 | NCB_Boot(CS2) |

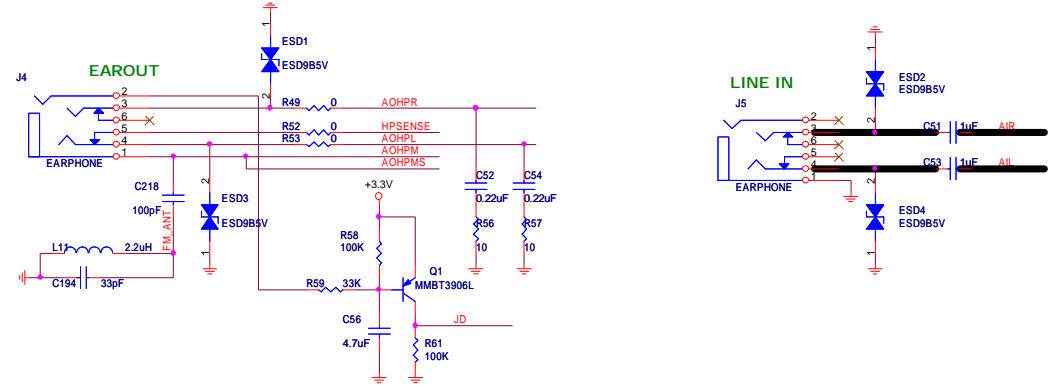
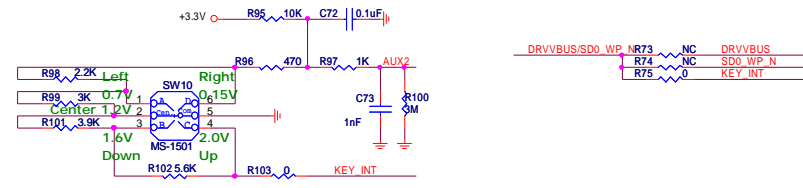

The AOHPMS and AOHPM must be connected at terminate, near the headphone Jack

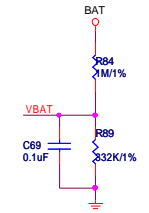
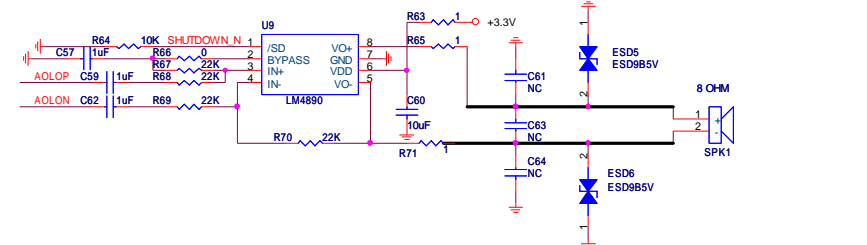

AUDIO

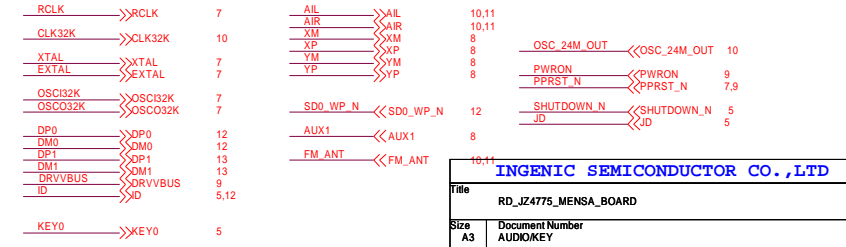

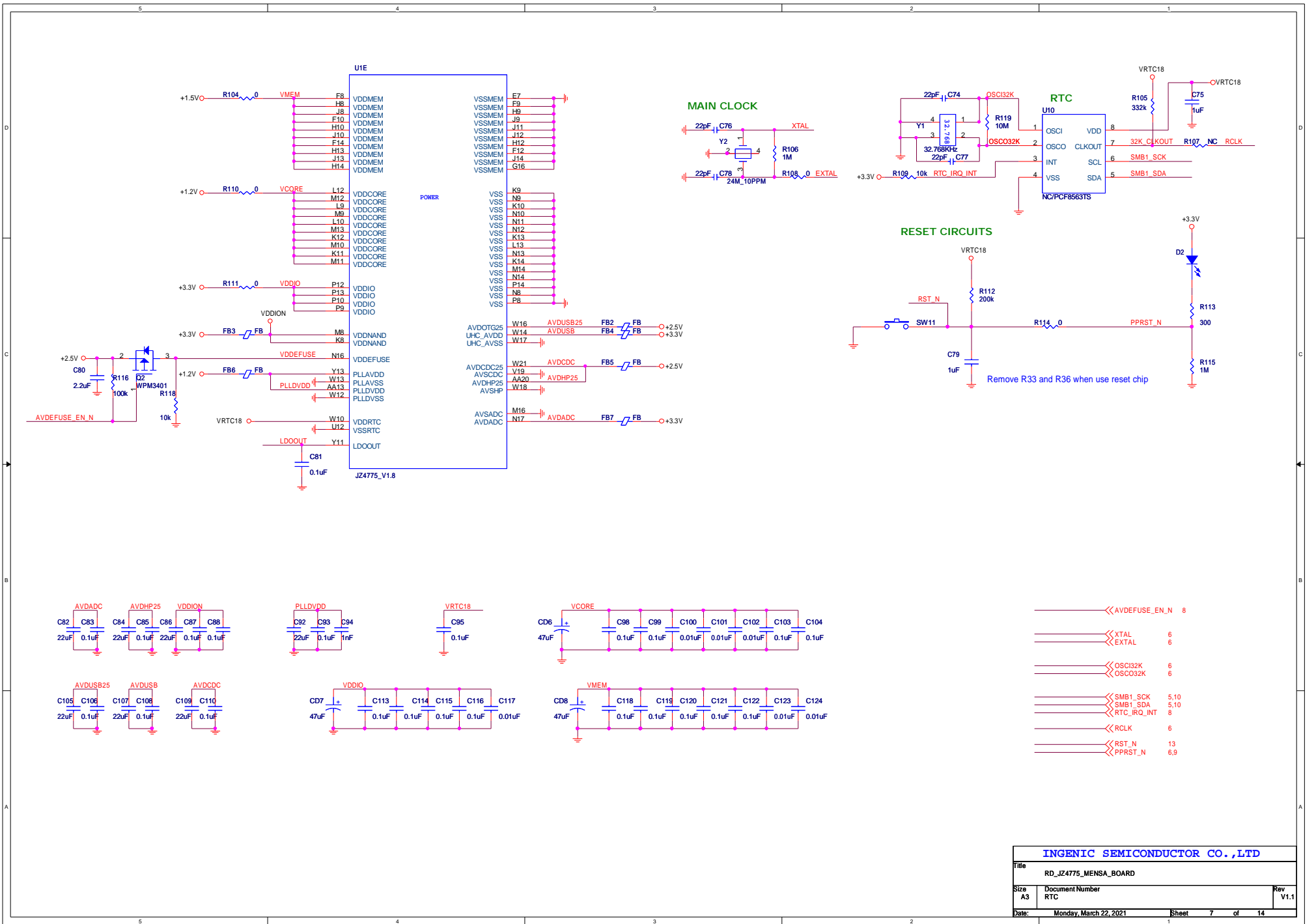

| | | |
|---------------------------------------|------------------------|-------------|
| INGENIC SEMICONDUCTOR CO., LTD | | |
| Title RD_IJ24775_MENSA_BOARD | | |
| Size A3 | Document Number RTC | Rev V1.1 |
| Date: Monday, March 22, 2021 | Sheet 7 | of 14 |

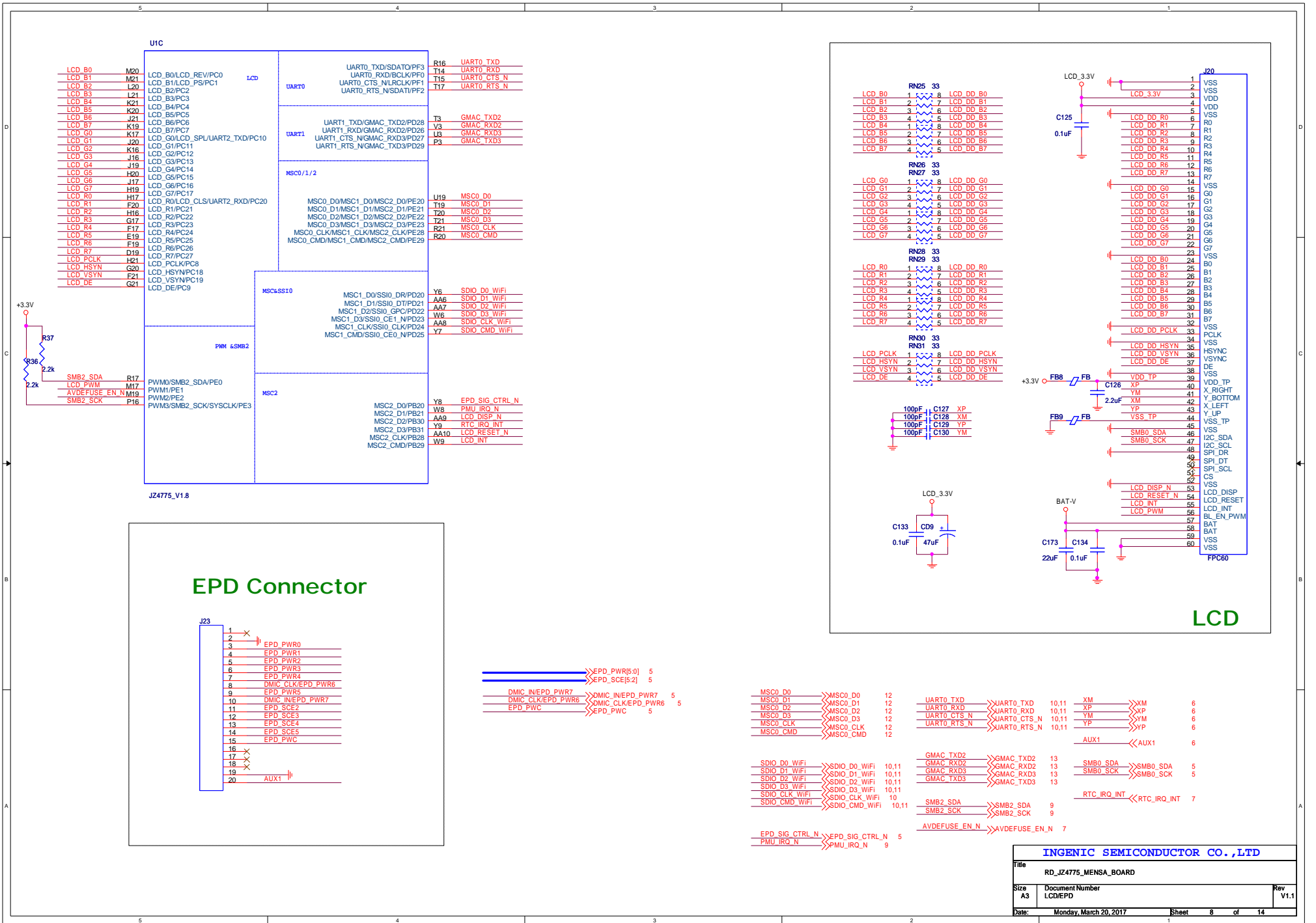

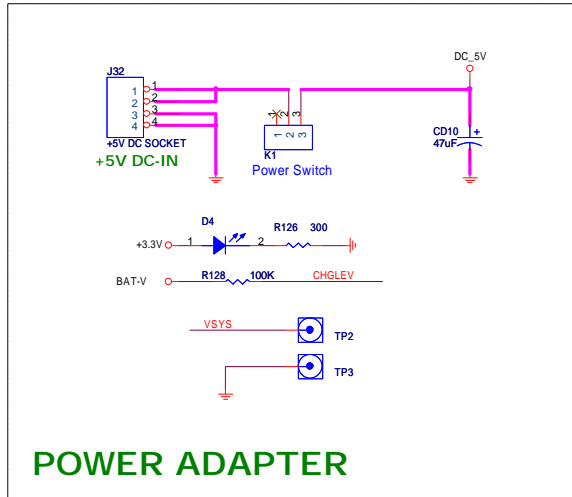

POWER ADAPTER

| | | |
|-----------|-------------|-----|
| PPRST_N | <<PPRST_N | 6,7 |
| PMU_IRQ_N | <<PMU_IRQ_N | 8 |
| SMB2_SCK | <<SMB2_SCK | 8 |
| SMB2_SDA | <<SMB2_SDA | 8 |
| PWRON | <<PWRON | 6 |
| DRVVBUS | <<DRVVBUS | 6 |

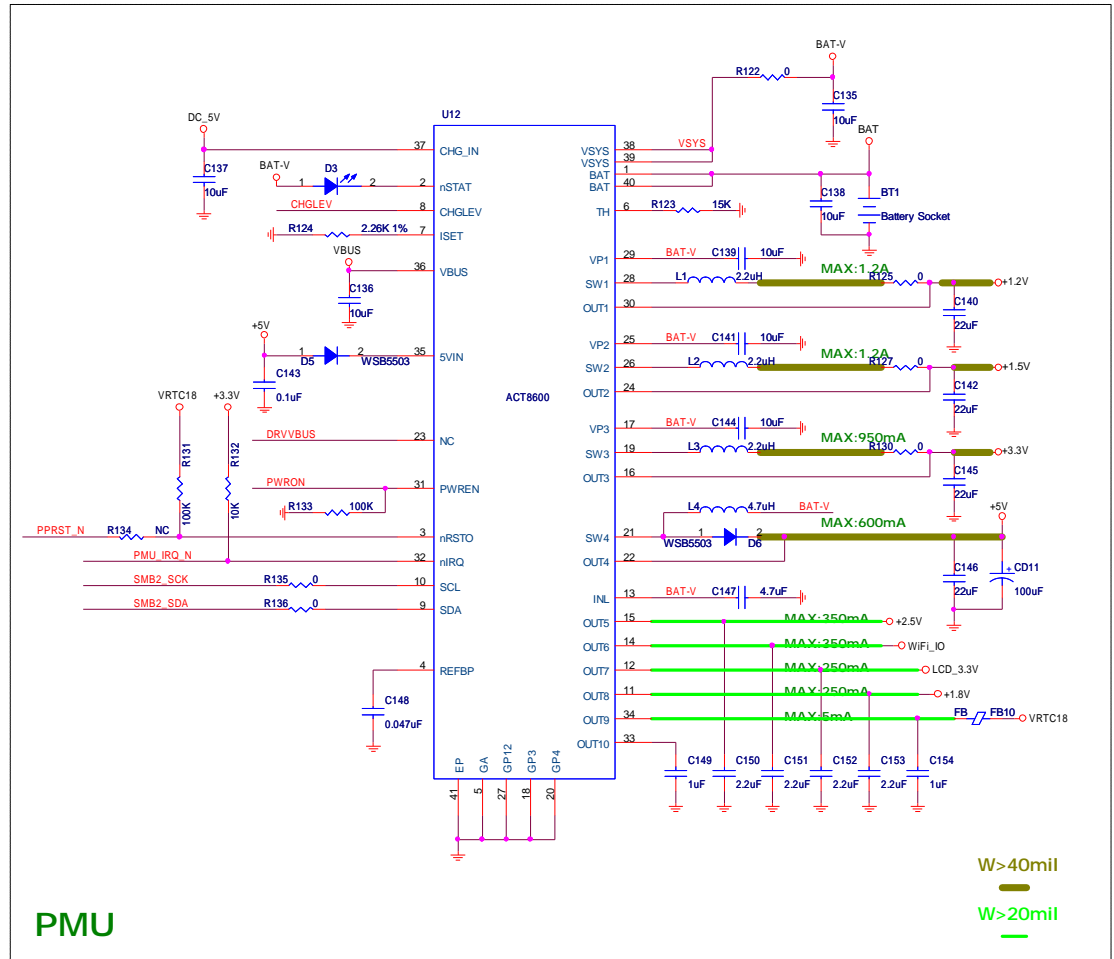

PMU

W>40mil
 W>20mil

| | | | |
|---------------------------------|------------------------|-------------|--|
| INGENIC SEMICONDUCTOR CO.,LTD | | | |
| Title RD_IJ4775_MENSA_BOARD | | | |
| Size A3 | Document Number PMU | Rev V1.1 | |
| Date: Monday, March 20, 2017 | Sheet 9 | of 14 | |

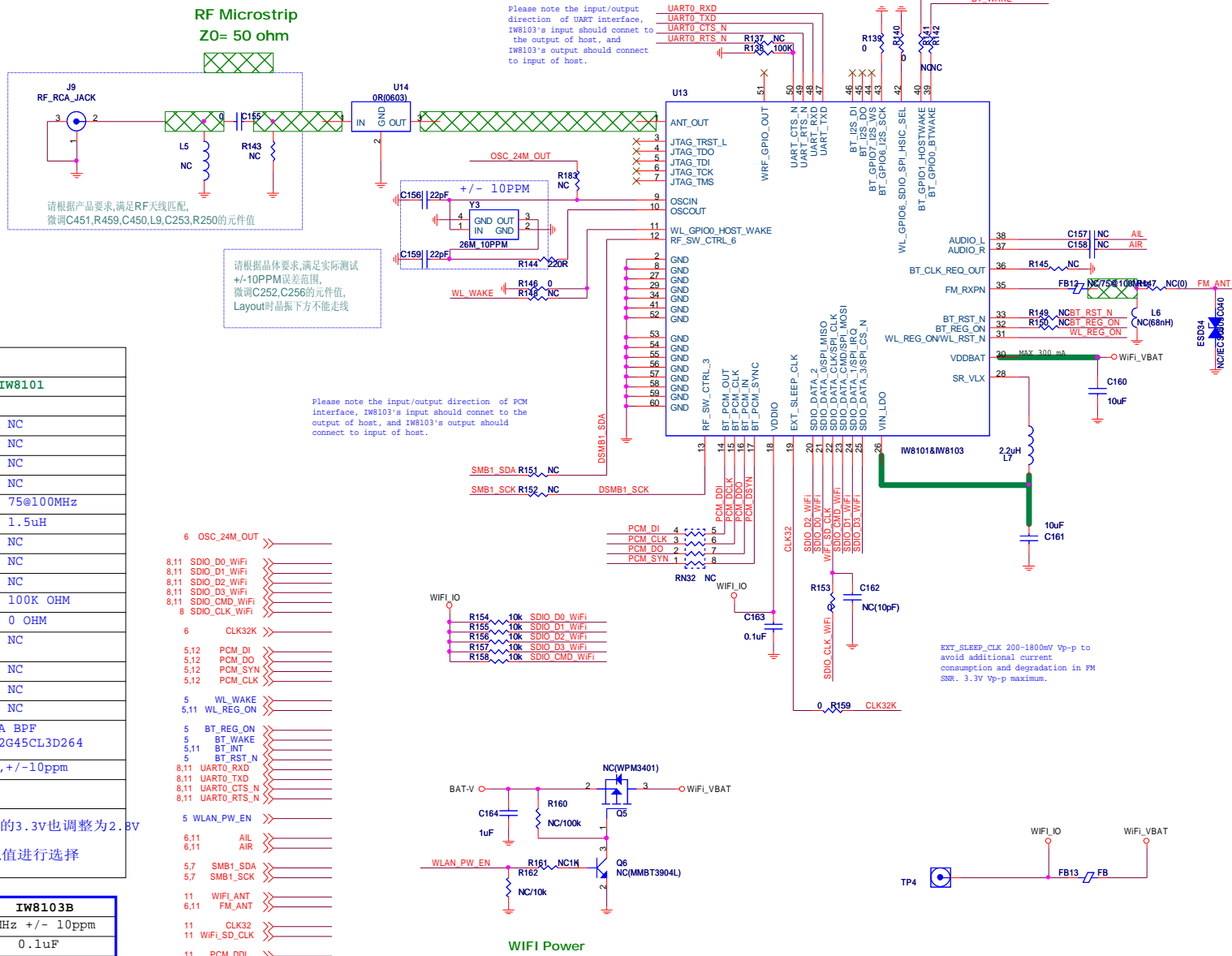

Component select in IW8101 & IW8103

| Part Number | IW8103 | IW8101 |
|---------------------|-------------------|-----------------------------|
| | value | |
| C157,C158 | 1uF | NC |
| C164 | 1uF | NC |
| ESD34 | TESB0R15V05B1X | NC |
| FB12 | 75@100MHz | NC |
| FB13 | NC | 75@100MHz |
| L7 | 2.2uH | 1.5uH |
| Q5 | WPM3401 | NC |
| Q6 | MMBT3904L | NC |
| RN32 | 0 OHM | NC |
| R138 | NC | 100K OHM |
| R139,R146 | NC | 0 OHM |
| R137,R141,R142,R147 | 0 OHM | NC |
| R148,R149,R150 | 100K OHM | NC |
| R160 | 10K OHM | NC |
| R162 | 1K OHM | NC |
| R161 | 1K OHM | NC |
| U14 | 0 OHM | MURATA BPF LFB182G45CL3D264 |
| Y3 | 37.4MHz, +/-10ppm | 26MHz, +/-10ppm |

备注

使用IW8103, WIFI_IO电压调整为2.8V,同时系统的3.3V也调整为2.8V

清单内无标识的物料为共用料, 请按原理图标识值进行选择

| 器件编号 | IW8103 | IW8103B |
|-----------|-------------------|-----------------|
| Y3 | 37.4MHz +/- 10ppm | 26MHz +/- 10ppm |
| C157,C158 | 1uF | 0.1uF |
| R151,R152 | NC | 0R |
| L7 | 2.2uH | 4.7uH |
| FB12 | 75@100MHz Bead | 100pF CAP |
| R140,R142 | 0R | NC |

- 6 OSC_24M_OUT >>>
- 8,11 SDIO_D0_WIFI >>>
- 8,11 SDIO_D1_WIFI >>>
- 8,11 SDIO_D2_WIFI >>>
- 8,11 SDIO_D3_WIFI >>>
- 8,11 SDIO_CMD_WIFI >>>
- 8 SDIO_CLK_WIFI >>>
- 6 CLK32K >>>
- 5,12 PCM_DI >>>
- 5,12 PCM_DO >>>
- 5,12 PCM_SYN >>>
- 5,12 PCM_CLK >>>
- 5 WL_WAKE >>>
- 5,11 WL_REG_ON >>>
- 5 BT_REG_ON >>>
- 5 BT_WAKE >>>
- 5,11 BT_INT >>>
- 5 BT_RST_N >>>
- 8,11 UART0_RXD >>>
- 8,11 UART0_TXD >>>
- 8,11 UART0_CTS_N >>>
- 8,11 UART0_RTS_N >>>
- 5 WLAN_PW_EN >>>
- 6,11 AIL >>>
- 6,11 AIR >>>
- 5,7 SMB1_SDA >>>
- 5,7 SMB1_SCK >>>
- 11 WIFL_ANT >>>
- 6,11 FM_ANT >>>
- 11 CLK32 >>>
- 11 WIFL_SD_CLK >>>
- 11 PCM_DDI >>>
- 11 PCM_DDO >>>
- 11 PCM_DSYN >>>
- 11 PCM_DCLK >>>
- 11 DSMB1_SDA >>>
- 11 DSMB1_SCK >>>

| | | | |
|--------------------------------------|------------------------------------|----------|--|
| INGENIC SEMICONDUCTOR CO.,LTD | | | |
| File RD_I24775_MENSA_BOARD | | | |
| Size A3 | Document Number WIFL_IW8101/IW8103 | Rev V1.1 | |
| Date: Monday, March 20, 2017 | Sheet 10 | of 14 | |

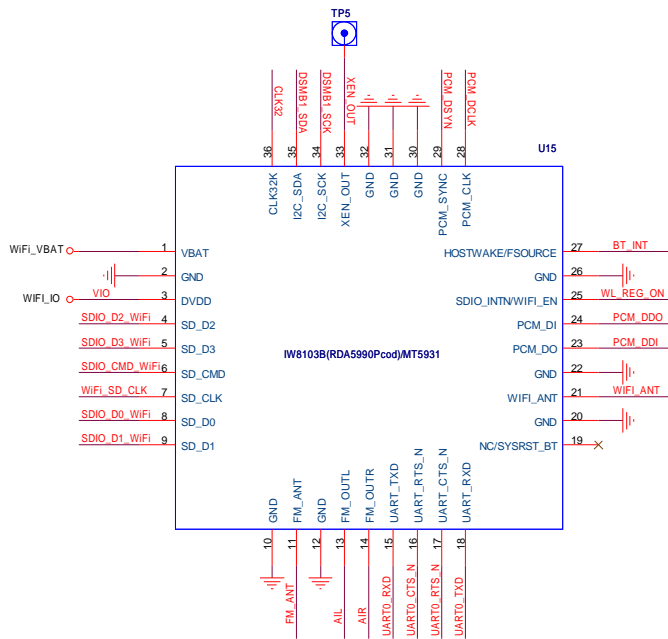

- 8,10 SDIO_D0_WIFI
- 8,10 SDIO_D1_WIFI
- 8,10 SDIO_D2_WIFI
- 8,10 SDIO_D3_WIFI
- 8,10 SDIO_CMD_WIFI
- 10 WIFI_SD_CLK
- 10 CLK32
- 5,10 WL_REG_ON
- 5,10 BT_INT
- 8,10 UART0_RXD
- 8,10 UART0_TXD
- 8,10 UART0_CTS_N
- 8,10 UART0_RTS_N
- 6,10 AIL
- 6,10 AIR
- 10 WIFI_ANT
- 6,10 FM_ANT
- 10 PCM_DDI
- 10 PCM_DDO
- 10 PCM_DSYN
- 10 PCM_DCLK
- 10 DSMB1_SDA
- 10 DSMB1_SCK

| | | |
|--------------------------------------|---------------------------------------|-------------|
| INGENIC SEMICONDUCTOR CO.,LTD | | |
| Title RD_IJ4775_MENSA_BOARD | | |
| Size A3 | Document Number WIFI_IW8103BMT5931 | Rev V1.1 |
| Date: Monday, March 22, 2021 | Sheet 11 | of 14 |

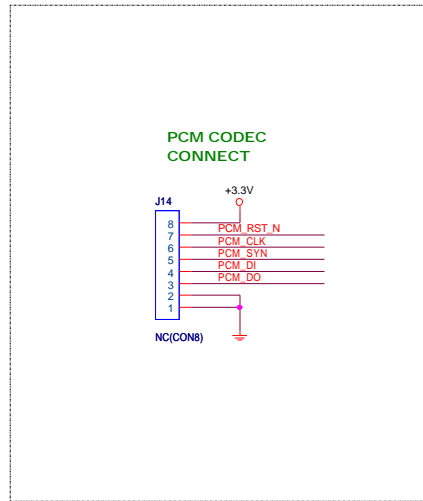
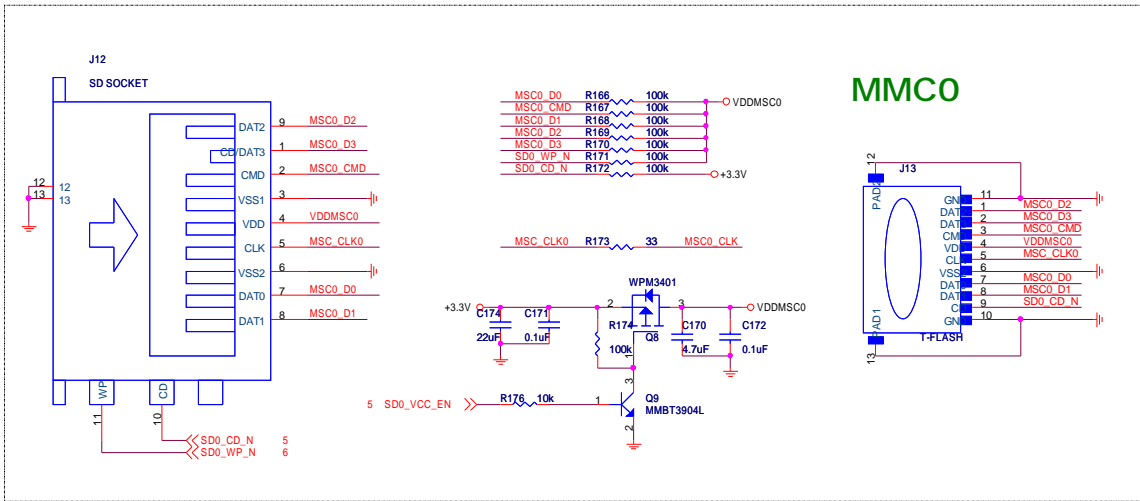
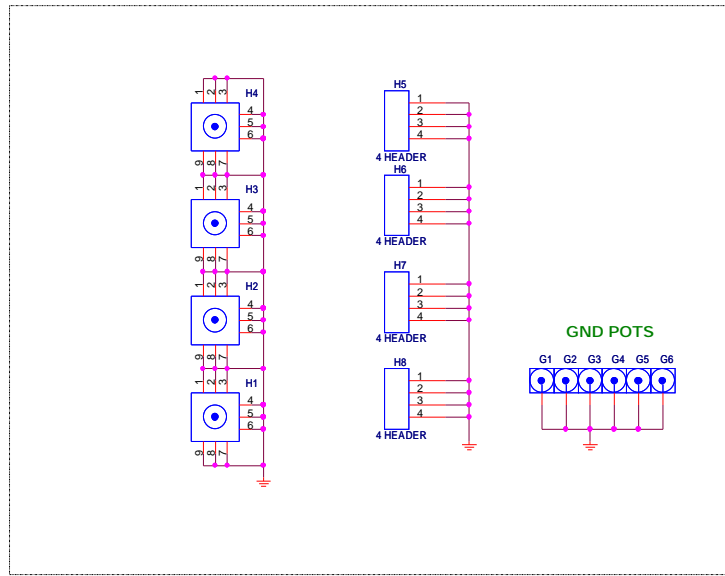
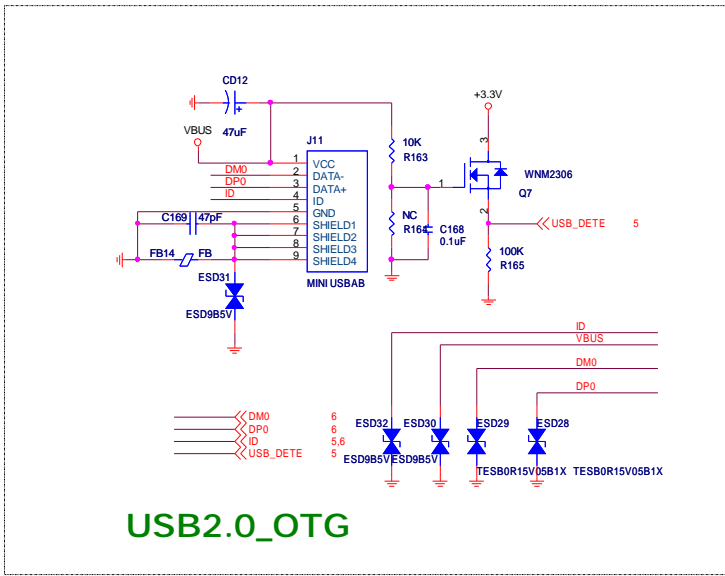

| | | | |
|--------------------------------------|--|-------------|--|
| INGENIC SEMICONDUCTOR CO.,LTD | | | |
| Title RD_IJ4775_MENSA_BOARD | | | |
| Size A3 | Document Number USB OTG/SD CARD/PCM | Rev V1.1 | |
| Date: Monday, March 20, 2017 | Sheet 12 | of 14 | |

Ethernet & USB Con

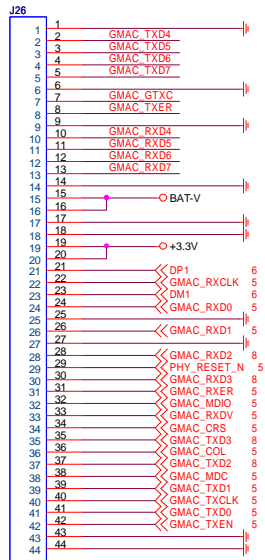

Ethernet & USB Con

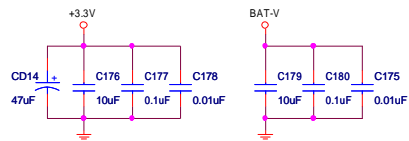

JDI & Uart Con

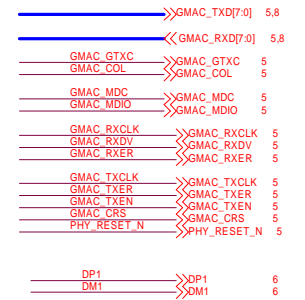
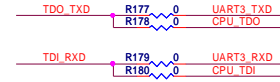
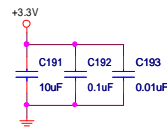
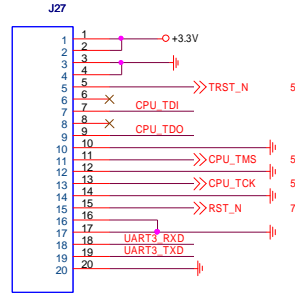

INGENIC SEMICONDUCTOR CO.,LTD

| | | |
|-----------------------|------------------------|----------------|
| Title | | |
| RD_IJ4775_MENSA_BOARD | | |
| Size | Document Number | Rev |
| A3 | DEBUG | V1.1 |
| Date: | Monday, March 20, 2017 | Sheet 13 of 14 |

Data Revision Change

| Data | Revision | Change |
|-------------|----------|---|
| Jan 8 2013 | Rev1.0 | 1. First Revision |
| Feb 28 2013 | Rev1.0.1 | <ol style="list-style-type: none"> 1. PAGE06: Change the Package of D1 2. PAGE06: R82 change to NC&R87 change to 0R 3. PAGE07: The power of AVDADC connect to +3.3V 4. PAGE07: Add R119 for 32.768k crystal 5. PAGE07: NC the reset IC of U11 6. PAGE10: Q6 change to NC 7. Change the power of VRTC from VRTC33 TO VRTC18 for save power 8. Change out1 of PMU to +1.2V 9. Connect the J12.12&J12.13 to GND 10. Change the package of U1 11. PAGE12: NC R175 12. PAGE07: The power of the pull-up resistor R109 should +3.0 V power domain 13. PAGE09: Change the R134 to NC 14. PAGE05: Exchange the net of DMIC_CLK/EPD_PWR6 & DMIC_IN/EPD_PWR7 15. PAGE07: Connect the net of PLLAVDD and PLLDVDD 15. PAGE04: Add the resistor of R27,R76,R85,R90 |
| | | |

| | | |
|--------------------------------------|-------------------------------------|-------------|
| INGENIC SEMICONDUCTOR CO.,LTD | | |
| Title RD_IJ4775_MENSA_BOARD | | |
| Size A3 | Document Number REVISION HISTORY | Rev V1.1 |
| Date: Monday, March 22, 2021 | Sheet 14 | of 14 |